

PILLEN GROUP PAPER

EDITION 1 | 2023

CREATE HUMAN COMFORT AND SAVE ENERGY



**THE FAMILY COMPANY | CHECKOUT SYSTEMS |
DRAUGHT SCREENS | INFRARED HEATING | COUNTERS &
CABINETS | (DIGITAL) PRESENTATION DISPLAYS |
SHOPPING & INTERIOR ELEMENTS | SUSTAINABLE**

LOOKING TO PRODUCE?

Partner with the Pillen Group



Your idea or design?

Together we develop and produce your innovative products.

SO NICE TO SEE YOU!

Welcome to the Pillen Group, a family business which has been working nationally and internationally as an innovative production and assembly factory for over 65 years. As a family and a team, we enjoy meeting our business relations in person and investing in long-term partnerships.

Full-service partner for store and interior experience!

With 4 production and assembly sites in Lichtenvoorde, near Germany, and more than 125 skilled employees, we serve many (renowned) companies and designers in various markets to achieve the ultimate store and interior experience. With high-quality machinery, the decades of knowledge and experience of our people and with passion, we never avoid a challenge, however complex.

Dutch manufacturer

Having started as an engineering works in metal machining, Pillen has now developed into a full-service partner in manufacturing products from various materials.

Meet the Pillen family

My name is Theo Pillen, one of the second generation of family members working in the companies in the Pillen Group. Looking to the future, the younger generation of our family is also involved in the business to ensure that our innovative power, creativity and pure entrepreneurship continue to survive.

Do you have an idea and/or are you looking for a creative partner?

We are here for you. Kind regards,
Theo Pillen

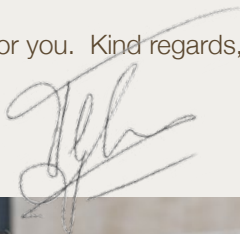

Bart, Anneke, Mark

Our knowledge of raw materials like steel, metal, wood, plastic, stone and glass and their processing has increased exponentially and can be described as unrivalled.

IMPOSSIBLE?

Let's make it possible together!

Original Equipment Manufacturer (OEM) for furniture and elements

Our strength lies in the production and manufacturability of products. This also includes an element of specialism involving engineering, product development and prototyping. We offer this service to partially or fully support our customer, as required.

Furthermore, we look after the entire project management with respect to production and assembly of the final product. If necessary, we can also arrange the transport of the products and provide aftersales services.



Theo Pillen - CEO

PILLEN CHECKOUT SYSTEMS



Every year, we deliver over 3000 ergonomic retail workplaces at a time when digital store concepts have also become commonplace. In this mix of traditional and digital store concepts, we want to develop the right systems for our relations and help them plan what the store of the future will look like and how it will evolve.

OUR CHECKOUT SYSTEMS

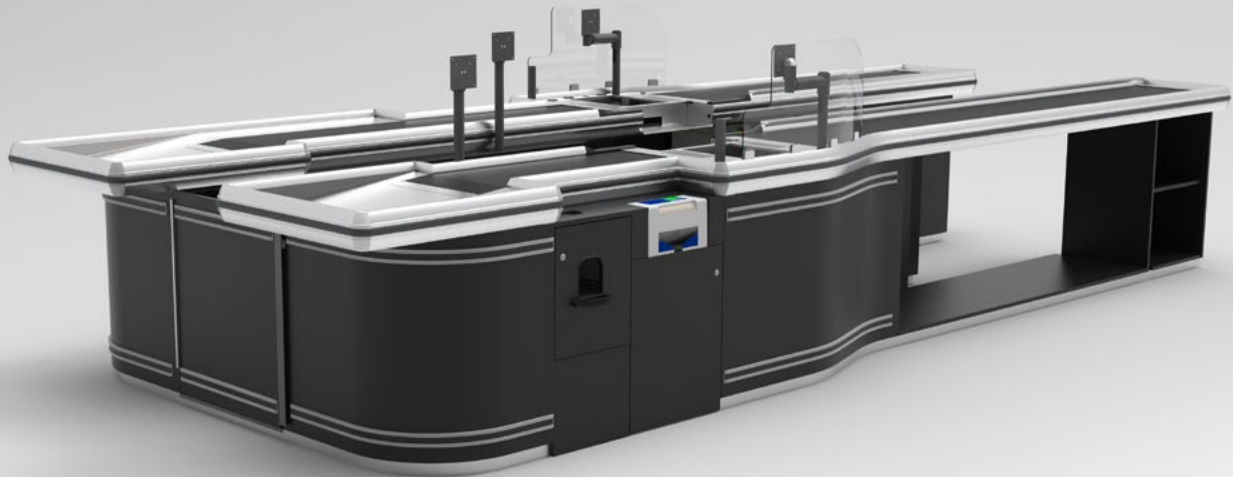

Model: Alu-woodline

Pillen Checkouts Systems

Since 1997, our checkout systems have become a familiar, stylish, high-quality and sustainable addition to the store and the total interior experience. We work for both small independent retailers and big department stores. The entrance and exit zone where the checkouts are located is an important area which gives a visitor their first and last impression of a store.

Healthy employees and satisfied customers

Retailers who prioritise the vitality and health of their employees can rely on us for customised advice. We develop and produce checkout systems which comply with the legal requirements for a workplace, aimed at offering checkout employees a pleasant and ergonomic workplace where they can serve customers with a smile.

Personal atmosphere

With our checkout systems, we provide a personal atmosphere in the store. The systems can be customised in terms of colours, logos, etc so that they seamlessly reflect the desired corporate style.

Circular - sustainable

For over 25 years, we have been building high-quality checkout systems with an almost indestructible technical lifespan. Today we call this sustainable, and we also produce circular checkout systems for which we make a conscious choice of raw materials. Together with our relations, we explore how our checkout systems can remain in use for longer.

We serve our customers at various circular levels. In doing so, we increasingly offer 'retrofit' concepts for existing systems, instantly revitalising a checkout system that is already years old. This not only saves costs but also makes a positive contribution to nature because no new product is made, and no old systems end up in landfill.



Model: Woodline

Our product range

Our portfolio of checkout systems consists of three versions which are produced to order.

1. Wooden checkout system (Wood-line)
2. An aluminium-wood checkout system (Alu-woodline)
3. Steel checkout system (Steelline)

Dimensions and colour combinations can obviously be tailored to the customer. Design, engineering, production, installation and (aftersales) service are other elements which we naturally manage ourselves.

Accessories

We have a limitless range of accessories consisting of:

- Checkout seating
- Cable trays
- Card readers and screen holders
- Cash systems
- Bag holders
- Camera surveillance
- Dividers
- Worktop trays
- Footrests
- Infrared heating
- Payment plateaus
- Protective sheets
- Barrier tapes
- Theft protection
- Checkout belt
- Signing options



Selfscan checkout

Who do we make checkout systems for?

- Supermarkets
- Drugstores
- Chemists
- Perfumeries & cosmetics stores
- Self-service wholesalers
- Garden centres
- DIY centres
- Leisure markets & recreation
- Pet shops
- etc.



More info? Scan the QR-code

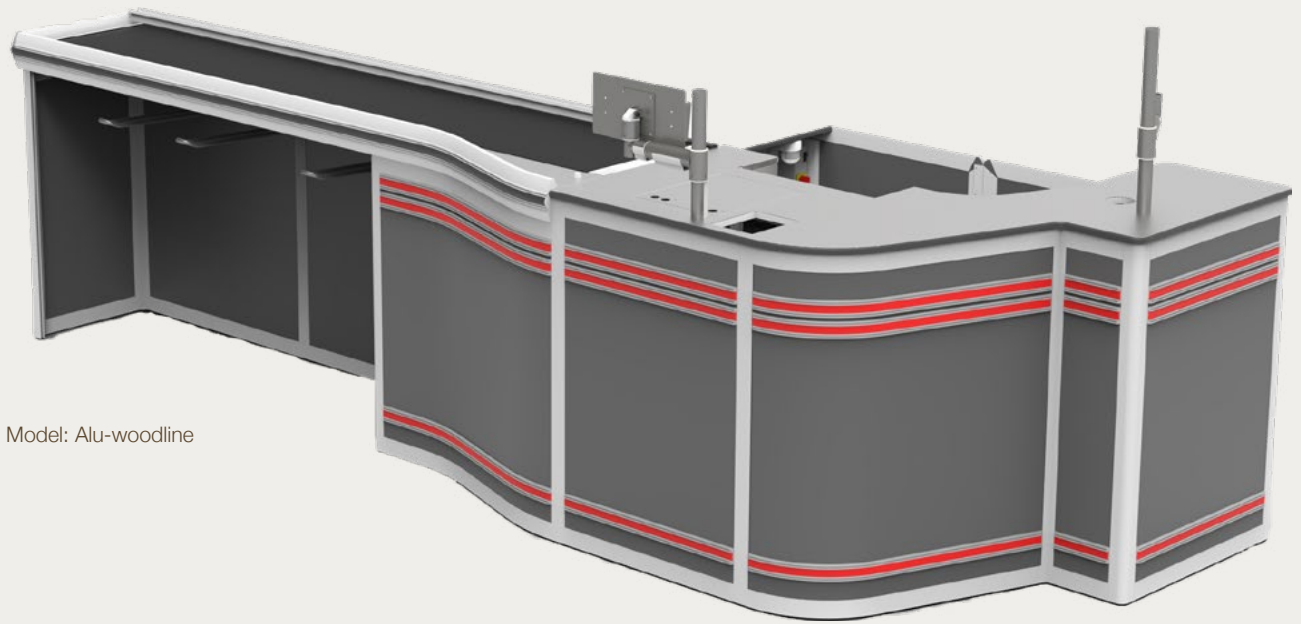

Model: Alu-woodline



Model: Woodline

BLOCK AND STOP THE WIND

Draught and cold is a frequently mentioned problem at entrances and exits of shops and other buildings. Windstop draught screens make cold and draughts a thing of the past. A cold draught can disrupt the comfort of a pleasantly heated workplace. Raising the temperature of the area or room does not solve the problem or improve comfort and is certainly not energy efficient.



BLOCK AND STOP THE WIND!

OUR WINDSTOP DRAUGHT SCREENS



Windstop draught screen

The alternative for an air curtain system

Installing a Windstop draught screen at the entrance and exit stops cold and draughts. The Windstop draught solutions are available in two standard versions. Other dimensions also possible on request.

Transparent

The draught screens are transparent so that you can look through them. This means that a view of the entrance or exit is not obstructed. The screen covers are easy to change and can be optionally designed to reflect your own style or corporate identity.

The solution for entrance and exit zones

An ideal solution for shops whose check-out is near an entrance or exit, a hotel reception or the reception desk at an office, school or municipal building.

Our Windstop products are designed and manufactured in the Netherlands. .



Schematic representation of Windstop

More info? Scan the QR-code



CREATE HUMAN COMFORT WITH INFRARED HEATING

INFRARED HEATING

Direct and effective infrared heating of workplaces and living environments instead of heating entire areas and buildings to the maximum.

Since 2007 we develop and produce infrared heating products. With HeatFun, we ensure that heating daily life becomes much more pleasant and comfortable.

Round infrared heating rings

HEAT Fun[®]
Human Comfort

OUR INFRARED HEATING

HEATFun
Infrared Heating



Also in combination with light!

HeatFun combines LED lighting and infrared heating from the ceiling in comfort panels designed in house. So that every workplace is optimally lit and heated with just 395 watts!



With infrared heating, you bring the natural heat of the sun indoors

Our infrared heating panels create a comfortable heat in an energy-efficient way. Energy is converted nearly 1 to 1 into radiation heat.

The simple installation involves no structural modifications. A plug is sufficient to immediately enjoy the heat. The infrared heating is frequently applied at entrance and exit zones of shops and buildings, offices, hospitality outlets and homes.



Round infrared rings

The round infrared heating rings are also unique and combine perfectly with your own lighting. Specially designed for an amazing 360-degree heat experience and available in different colours. The round heating is ideal for a lunchroom above tables,... hotel lobby above seating area,... meeting room above the table... or indoors at home.



Dust and water resistant (IP68)

Besides the movable infrared heating, wall heating and suspended ceiling solutions, the HeatFun range also includes dust and water-resistant infrared heating. Ideal for damp areas like bathrooms.

All our HeatFun products are designed and manufactured in the Netherlands.



More info? Scan the QR-code





Cooking desk

The place where customers can receive help if they have any questions about products or need advice requires an inviting and accessible unit for visitors that reflects the store experience and the interior. The counter workplace must also be ergonomically sound. We develop and produce counters and cabinets for various markets. The arrangement and form of the counter are essential to create a good customer-employee contact that reflects the total store experience.

These counters are usually also used as a sales service point and can be optionally fitted with matching cabinets, payment systems, etc.

OUR COUNTERS & CABINETS



Permanent place in the interior or a mobile variant

The counters can be permanently integrated in a store interior, but mobile versions are also commonly used.

From service to cooking

Counters are customer specific and can be customised with different functionalities. Our counters can therefore be found as:

- Service desk
- Sales desk
- Potting counter
- Packing and gift desk
- Ticket desk
- Service desk
- Hospitality desk
- Cooking desk



Who do we make these mobile desks and storage cabinets for?

- Supermarkets
- Drugstores
- Chemists
- Perfumeries & cosmetics stores
- Self-service wholesalers
- Garden centres
- DIY centres
- Leisure markets & recreation
- Pet shops
- Interior design
- Cinemas
- Hospitality industry
- Cooking studios
- etc.



More info?
Scan the QR-code



Products require good presentation. We develop, produce and assemble physical and digital displays to meet customer-specific requirements. We are seeing a growing demand among our customers for possibilities to combine the physical sales and associated advice with digitally available information (content) which the store visitor can view and consult themselves.

This development can be a valuable addition to store employees. But it also reflects how the shopping public wants to shop today with 24/7 access to information.



Stylish display cabinets

OUR PRESENTATION DISPLAYS



Digital presentation display with hygiën dispenser

The power of digital kiosks

Our (digital) POS, sales, information, ordering and payment terminals, kiosks and displays have multifunctional uses in many different stores and areas to replace or support the physical use of employees. We produce the hardware (the display) and in consultation with software suppliers, the display is produced as final product.

The digital presentation displays are used in the following areas:

- Stores
- Cinemas
- Hotels
- Restaurants
- Museums
- etc.



From idea to final product

We help our customers decide how the presentation display should look and are involved from idea and design to final product.

Stylish and sublime

Besides the digital presentation displays that we can deliver to stores, restaurants or museums, we can also create the most stylish display cabinets as presentation kiosks which are truly sublime and high quality.



More info? Scan the QR-code



We design and translate your brand and corporate style to each interior with our interior elements! Making beautiful things is an art but ultimately it is about the function and the goal. Our products instantly promote the ideal experience in new and existing interiors.



Ceiling elements

OUR SHOPPING & INTERIOR ELEMENTS



Floating curved ceiling elements with LED lighting

Because we develop, design and produce all our systems and elements in our own assembly factory in the Netherlands, we can customise different variants of interior experience and signing elements for a range of applications.

Plug & Play

With our store experience and interior elements, we are renowned for delivering this 'Plug & Play', without requiring modifications to the structural part of a building. Assembly can be performed on site if necessary. The customer decides on the material, the form, dimensions as well as colour and print combinations.

This effortlessly gives the element its unique style. Furthermore, our products can be combined with led lighting, infrared heating, acoustic elements, etc.

Good acoustics, more experience, more comfort

If desired, we can also add sound-absorbing materials to our interior elements to audibly improve the acoustics.

Some of our interior elements

- Suspended ceiling elements in linear and curved forms
- Freestanding objects: mobile walls and hygienic walls
- Full-size wall panels
- Signing and corporate style communications on various (checkout) systems, counters, etc.

We create interior elements for the following markets:

- Stores
- Interior design
- Hospitality industry
- Cinemas
- Museums
- Schools
- Offices
- etc.

Been inspired? Let us help with ideas.

More info? Scan the QR-code



Fullsize wall panel



CHOOSE FOR A SUSTAINABLE & ERGONOMIC FUTURE

As a full-service partner for relations in different markets like retail, interior construction, hospitality, recreation, entertainment and real estate, we are conscious of our footprint.

Together, we take responsibility

Everyone can see that our climate is changing rapidly. As a manufacturing company, we are conscious that we can and must make a difference. It may only be a drop in the ocean but every little helps, and lots of little things can ultimately have a huge impact on tackling climate change.

Transition to sustainability

We are therefore making our buildings and machinery more sustainable, and together with and for our customers we choose sustainable raw materials which can be incorporated and processed in a final product.

All this is aimed at reducing emissions and contributing to a circular production environment in which our systems and elements must contribute to a sustainable future for the next generations.

Sustainable use and ergonomically sound

Besides improving the sustainability of our buildings, production and logistics processes for our final products, we also feel that it's extremely important that our own employees continue to develop to stay relevant, inside and outside the labour process. Just as we want to create ergonomically sound products for our customers, we also attach great importance to ergonomic and comfortable workplaces in our companies.

**WE HAVE BEEN
MAKING DESIGN
PRODUCTS FOR
MORE THAN 65
YEARS**

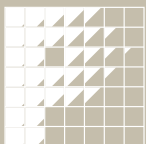

Pillen
GROUP

Let's talk

Nijverheidsstraat 9
7131 PA Lichtenvoorde (NL)
+31 (0)544 - 390 000
info@pillen.eu
www.pillen.eu

Postbus 75
7130 AB Lichtenvoorde (NL)

